



DC MOTOR

7 watt

Precious Metal Brushes

2-40/07 __ -5

TRIDENT ENGINEERING LIMITED
Trident House, King Street Lane,
Winnersh, Wokingham,
Berkshire, RG41 5AS

Telephone: 0118 978 6444

Fax: 0118 977 6345

Email: sales@tridenteng.co.uk

www.tridenteng.co.uk

Stock Voltages		06	09	12	15	18	24	30
1. Nominal voltage	Volt	6	9	12	15	18	24	30
2. No-load speed	rpm	3780	4050	3780	3940	4050	3980	3940
3. No-load current	mA	61	45	30	26	22	16	13
4. Nominal Torque	mNm	22	22	22	22	22	22	22
5. Starting torque	mNm	74	85	77	85	89	87	86
6. Torque constant	mNm/A	15.0	21.0	30.0	36.0	42.0	57.0	72.0
7. Nominal Speed	rpm	2650	3010	2700	2920	3050	2980	2930
8. Nominal Current	mA	1520	1090	760	630	540	400	320
9. Terminal Resistance	Ohm	1.2	3.7	6.3	10.1	14.1	25.1	25.1
10. Rotor Inductance	mH	0.15	0.29	0.59	0.85	1.16	2.14	3.41
11. Rotor Moment of Inertia	kgm ²	4x10 ⁻⁶	4x10 ⁻⁶	4x10 ⁻⁶	4x10 ⁻⁶	4x10 ⁻⁶	4x10 ⁻⁶	4x10 ⁻⁶
12. Mechanical time constant	ms	19	19	19	19	19	19	19
13. Ambient temp. range operating	°C	-10/+60						
14. Thermal resistance winding-housing	K/W	5.5	5.5	5.5	5.5	5.5	5.5	5.5
15. Weight	gram	200						
16. Bearings type		sleeve						

Product combinations

Gearheads GS38, GS40

Encoders HEDS

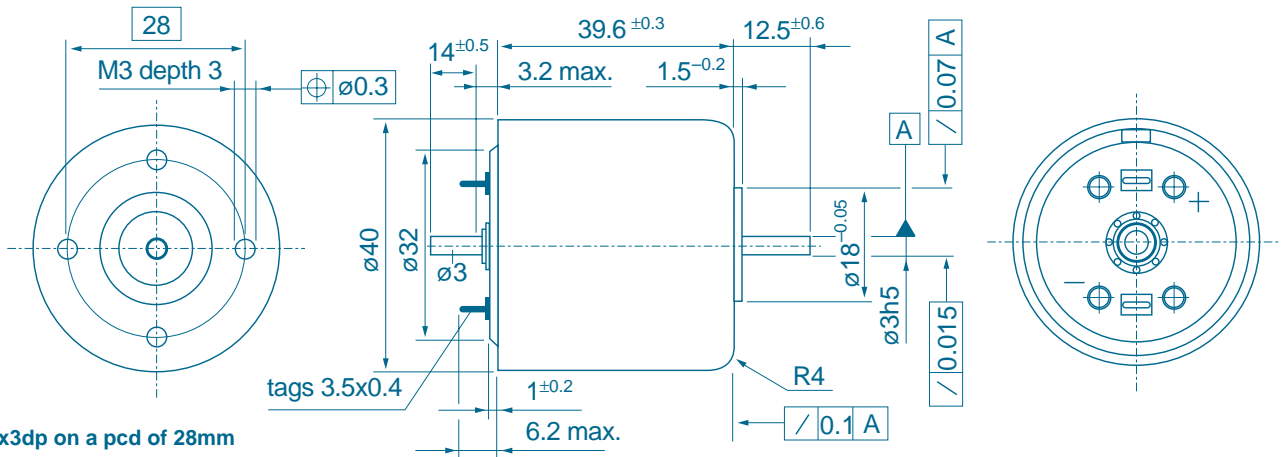

Notes

