

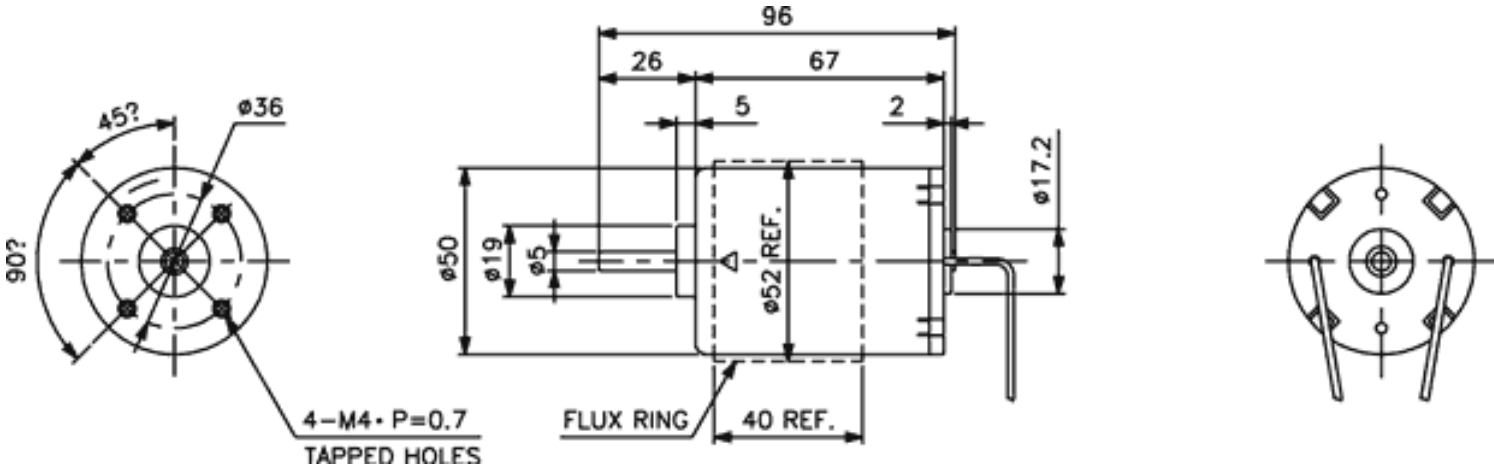

Weight: 435g (approx)

**Dimensions (mm)**



**Specification**

Model No.	No Load			Max Efficiency							Stall			
	Voltage	Speed	Current	Speed	Torque			Current	Output	Eff.	Torque			Current
<a href="#">How to read the model numbers</a>	V	RPM	A	RPM	mN-m	g-cm	oz-in	A	W	%	mN-m	g-cm	oz-in	A
H5067-007-GF-7	12	25480	4.7	21400	84.4	861	12.0	24.2	190	65.2	527	5380	74.7	127
H5067-012-GF-7	13.5	17800	2.0	15800	58.6	598	8.30	10.8	97.3	66.6	521	5320	73.9	80.5
H5067-015-GF-7	24	22460	1.9	19400	88.2	900	12.5	12.0	180	62.5	648	6610	91.8	76.0
H5067-028-GF-7	36	22844	1.07	19600	83.4	851	11.8	6.54	172	73.0	587	5990	83.3	39.6

**Characteristic Curves**