

Stepper Motor 57SH51 High Torque Hybrid

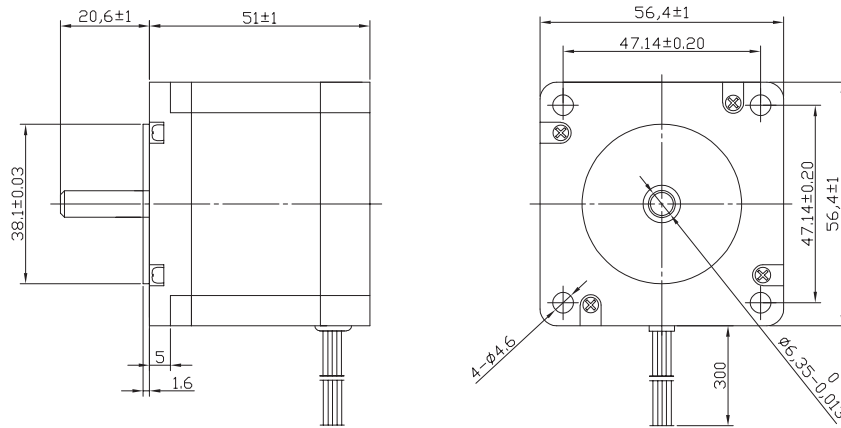

Characteristics

STEP ANGLE
1,8°

STEP ANGLE ACCURACY
± 5%

INSULATION CLASS
B

AMBIENT TEMPERATURE
-20°C +50°C

TEMP. RISE
80°C MAX (RATED CURRENT, 2 PHASE ON)

INSULATION RESISTANCE
100 M OHM MIN. 500 VDC

DIELECTRIC STRENGTH
500 VAC FOR ONE MINUTE

SHAFT RADIAL PLAY
0,02 MAX (450 G LOAD)

SHAFT AXIAL PLAY
0,08 MAX. (450 G LOAD)

MAX RADIAL FORCE
75 N (20 MM FROM FRONT FLANGE)

MAX AXIAL FORCE
15 N

Specification

Model	57SH51-1A	57SH51-2A	57SH51-3A	57SH51-4A
1 RATED VOLTAGE V	6,6	3,3	2,2	2,3
2 CURRENT/PHASE A	1	2	3	2,8
3 RESISTANCE/PHASE Ω	6,6	1,65	0,74	0,83
4 INDUCTANCE/PHASE MH	8,2	2,2	0,9	2,2
5 HOLDING TORQUE NM	0,72	0,72	0,72	1,01
6 ROTOR INERTIA G-CM ²	275	275	275	275
7 WEIGHT KG	0,65	0,65	0,65	0,65
8 NUMBER OF LEADS N°	6	6	6	4

Speed vs. Torque Characteristics

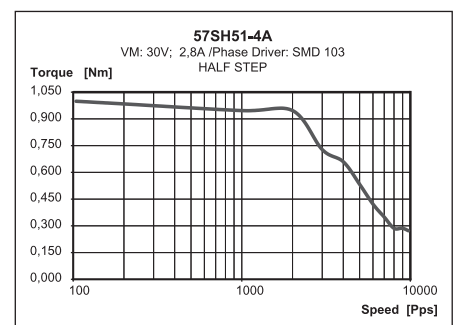
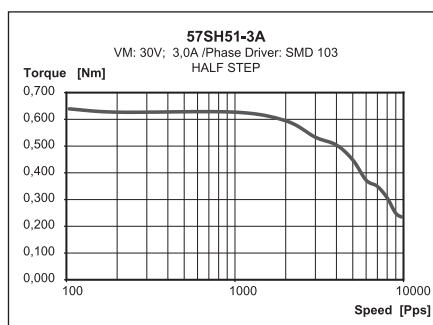
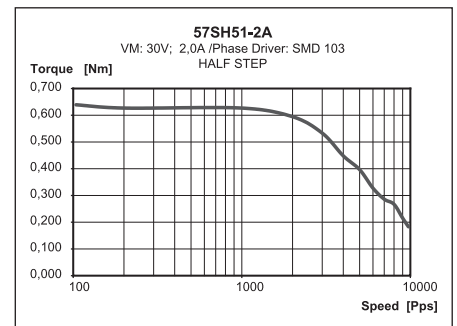
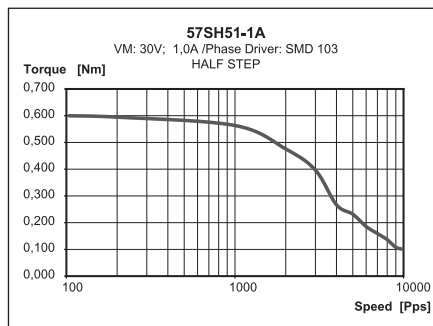

Connection

LEAD N°	COLOR	GAUGE	FUNCTION
1	BLACK	UL1430 AWG22	PHASE A
2	GREEN	UL1430 AWG22	PHASE A-
3	RED	UL1430 AWG22	PHASE B
4	BLUE	UL1430 AWG22	PHASE B-
UNIPOLAR MOTOR			
5	YELLOW	UL1430 AWG22	COM PHASE A
6	WHITE	UL1430 AWG22	COM PHASE B